



LED Light Bar Kit Installation Instructions – Maxx Slash®

Covers Parts #10290



Kit Contents:

- High-Voltage Power Amplifier
- Wire mounts (2)
- 3x6mm button-head screws (2)
- 3x12mm button-head screws (2)
- Front bumper with LED light bar
- Rear bumper with LED light bar
- Zip ties (9)

Tools needed:

- 1.5mm hex wrench
- 2.0mm hex wrench
- 2.5mm hex wrench
- Needle nose pliers

Compatible with the following Traxxas electronic speed controls (sold separately):

- Velineon® VXL-4s (part #3465)
- Velineon® VXL-6s (part #3485)
- Velineon® VXL-8s (part #3496)

High-Voltage Power Amplifier Installation:

1. Use needle nose pliers to remove the accessory port cover from the ESC (Fig. 1).
2. Install the high-voltage power amplifier [A] on the truck chassis. Ensure that the connection ports labeled "A, B, C, D" on the amplifier face towards the speed control. Secure with the included 3x12mm button-head screws (2). (Fig. 2)
3. Plug the 8-pin connector from the high-voltage power amplifier into the accessory port on the ESC; note orientation of the connector (Fig. 3). The amplifier and lights will turn on when the ESC is powered on.

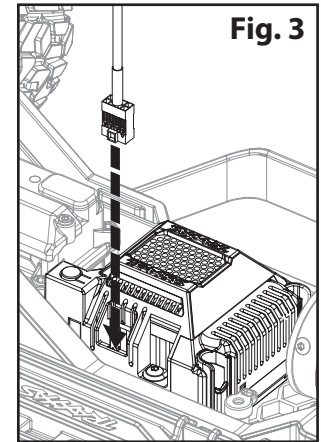
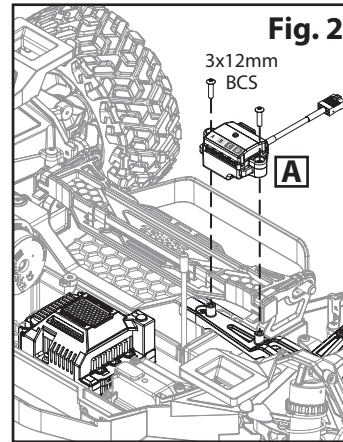
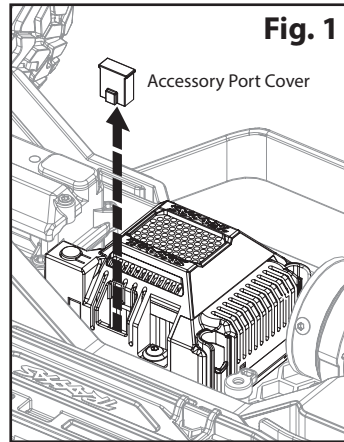

Front and Rear Bumpers/LED Light Bar Installation:

1. Remove the existing front bumper [B] from the bumper mount by removing the 4x12mm button-head cap screws (4) and 4x15mm button-head cap screws (2). Retain and reuse the screws. (Fig. 4)
2. Remove the existing rear bumper [C] from the bumper mount by removing the 4x12mm button-head cap screws (4). Retain and reuse the screws. (Fig. 4)
3. Install the two included wire mounts [D] on the chassis using the included 3x6mm button-head cap screws (2) in the locations shown in Fig. 5.
4. Install the new front bumper with LED light bar [E] using the 4x12mm button-head cap screws (4) and 4x15mm button-head cap screws (2) removed in step 1. (Fig. 5)

Fig. 4

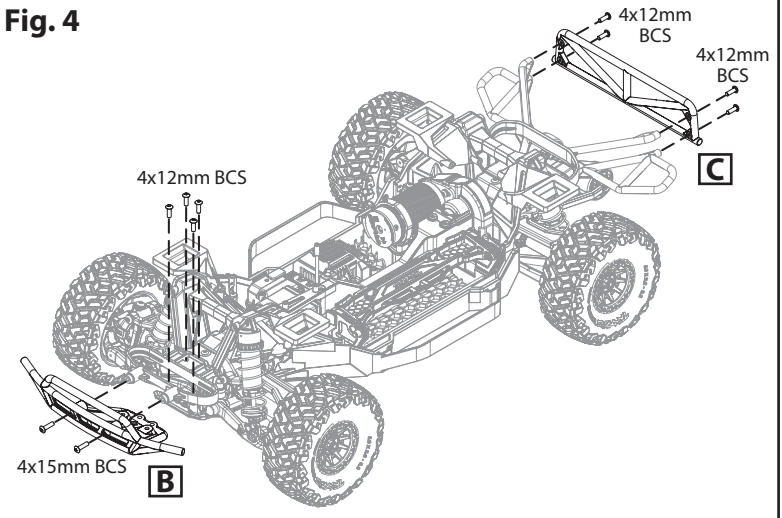
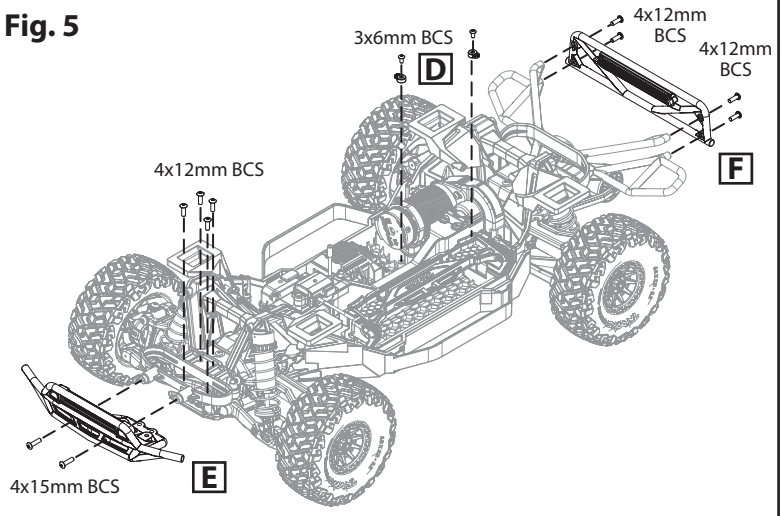

Fig. 5



CAUTION! To prevent damage to the electronic speed control (ESC) and/or the high-voltage power amplifier, ensure the battery is disconnected before plugging the amplifier into the ESC.

5. Plug the connector into the high-voltage power amplifier port A (white) (Fig.6).
6. Install the new rear bumper with LED light bar [F] using the 4x12mm button-head cap screws (4) removed in step 2. (Fig. 5)
7. Plug the connectors (red and blue) into the high-voltage power amplifier ports (red connector to C, blue connector to D) (Fig. 6).
8. Use the supplied zip ties to secure all wiring to the chassis (Fig. 7).

High-Voltage Power Amplifier Connection Ports

Fig. 6

- Front LED Light Bar (white)
- Rear LED Light Bar (tail lights) (red)
- Rear LED Light Bar (reverse lights) (blue)

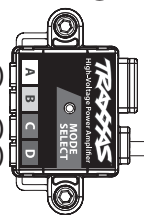

Wiring Diagram

Fig. 7

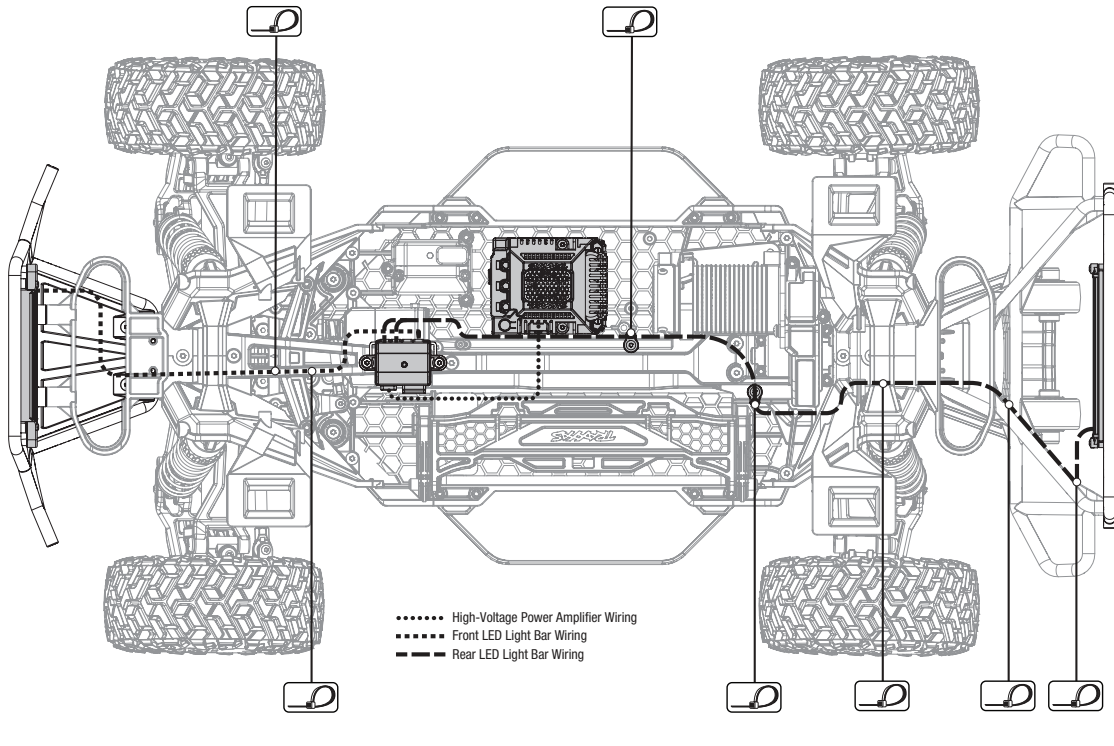

Front Light Bar Wiring

- Route the wiring from the front light bar under the bumper mount.
- Leave slack in the wire to allow for bumper movement while driving.



Rear Light Bar Wiring

- Route the wiring from the rear light bar under the bumper mount screw boss to allow for body clearance.



High-Voltage Power Amplifier Operation

Default Setting: Low Beam Mode

Connector	Channel	Default Connection	Default Setting
A	1	Low Beam Headlights	On
	2	High Beam Headlights	Off
B	3	Not used	N/A
	4	Not used	N/A
C	5	Tail Lights	On
	6	Brake Lights	On when braking
D	7	Reverse Lights	On when reversing
	8	Not used	N/A



Change the high-voltage power amplifier settings and gain access to additional functions using the Traxxas Link App (available in the Apple App StoreSM or on Google PlayTM). The TQi transmitter with the Traxxas Link Wireless Module (part #6511, sold separately) are required.

This device complies with FCC Part 15 & IC RSS-210 rules subject to the following conditions: (1) This device may not cause harmful interference, and (2) This device must accept all interference received, including interference that may cause undesired operation.

App Store is a service mark of Apple Inc. Google Play is a trademark of Google Inc.

High-Voltage Power Amplifier Mode Selection

Use the **Mode Select** button on the high-voltage power amplifier to toggle through the different lighting modes (from **Low Beam Mode** to **High Beam Mode** to **Daytime Mode**).

Connector	Channel	Default Connection	Low Beam Mode	High Beam Mode	Daytime Mode
A	1	Front Low Beam Headlights	On	Off	Off
	2	Front High Beam Headlights	Off	On	Off
B	3	Not used	N/A	N/A	N/A
	4	Not used	N/A	N/A	N/A
C	5	Tail Lights	On	On	Off
	6	Brake Lights	On when braking	On when braking	On when braking
D	7	Reverse Lights	On when reversing	On when reversing	On when reversing
	8	Not used	N/A	N/A	N/A

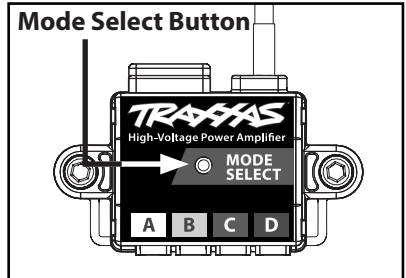

Warranty Information

Traxxas electronic components are warranted to be free from defects in materials and workmanship for a period of 30 days from the date of purchase.

Limitations: Any and all warranty coverage does not cover replacement of parts and components damaged by abuse, neglect, improper or unreasonable use, crash damage, water or excessive moisture, chemical damage, improper or infrequent maintenance, accident, unauthorized alteration or modification or items that are considered consumable. Traxxas will not pay for the cost of shipping or transportation of a defective component to us.

Traxxas Lifetime Electronics Limited Warranty

After the expiration date of the warranty period, Traxxas will repair electronic components for a flat rate. Please visit Traxxas.com/support for a current schedule of warranty costs and fees. The covered repairs are limited to non-mechanical components that have NOT been subjected to abuse, misuse, or neglect. Products damaged by intentional abuse, misuse, or neglect may be subject to additional charges. Traxxas liability, in no case, shall be greater than the actual purchase price of this product. For replacement, product must be returned in brand new condition, with packaging and itemized sales receipt.